



Installation and operating instructions

Water level controller and limiter

RBJ 54

RBJ 64

D-07-B-16632-EN-0.doc

Edition 07/2016

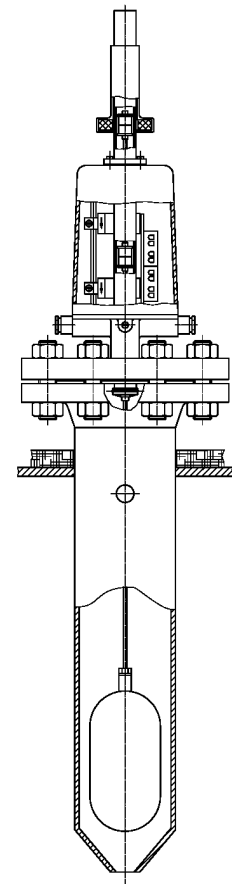

- ⓘ Table of contents-

| | | |
|------------|--|--------------|
| 1. | Health and safety instructions | 4-5 |
| 1.1 | General health and safety instructions | 4 |
| 1.2 | Unit-specific safety instructions | 5 |
| 1.3 | Exclusion of liability | 5 |
| 2. | Important information | 6 |
| 2.1 | Intended use | 6 |
| 3. | Explanations | 6 |
| 3.1 | Scope of supply | 6 |
| 3.2 | System description | 6 |
| 3.3 | Function | 6 |
| 4. | Technical data | 7-8 |
| 4.1 | Versions | 7 |
| 4.2 | Type of connection | 8 |
| 4.3 | Materials | 8 |
| 4.4 | Application limits | 8 |
| 4.5 | Corrosion resistance | 8 |
| 4.6 | Identification plate / Marking | 8 |
| 5. | Construction | 9 |
| 6. | Assembly | 10 |
| 7. | Electrical connection | 11-12 |
| 7.1 | Wiring diagram | 11-12 |
| 7.2 | Connection magnetic switch | 12 |
| 7.3 | Technical data magnetic switch | 12 |
| 8. | Commissioning | 12 |
| 9. | Operation monitoring | 12 |
| 9.1 | Function test..... | 12 |
| 10. | Maintenance | 13-14 |
| 10.1 | Exchange of float device..... | 14 |
| 10.2 | Assembly | 14 |
| 10.3 | Tightening torques..... | 14 |

| | |
|--------------------------------------|--------------|
| 11. Spare parts | 15 |
| 11.1 Float switch | 15 |
| 12. Decommissioning | 15 |
| 12.1 Disposal | 15 |
| 13. Supplement | 16-17 |
| 13.1 Warranty | 16 |
| 13.2 Declaration of Conformity | 17 |



Safety instructions



General health and safety instructions

1. Avoidance of danger for persons and property

- Only use unit for intended purpose.
- No additional mountings and modifications on the unit without our approval.
- Adhere to the standards for prevention of accidents and to the plant specific safety regulations.
- Read and observe installation and operating instructions.

2. Application limits

Only use this unit according to these operating instructions and to the parameters agreed upon in the delivery contract (see identification plate) including the agreed operating conditions.

3. Avoidance of danger and damages

- Distribute these mounting and operating instructions to appropriate department "arrival of goods, works transport, mounting, commissioning and maintenance".
- When passing the unit to a third party, these mounting and operating instructions must be enclosed in the national language of this third party.
- Only skilled and qualified personnel with special work order may work on the unit, which must be free of pipeline stress!
- Carefully read, observe and preserve these mounting and operating instructions.
- **Observe and adhere to the precautions marked in bold characters in the sections of these mounting and operating instructions!**
- Avoid shocks and impacts during transport, which could damage the unit.
- In case of intermediate storage take care for a dry and appropriate place where the unit cannot be damaged.

4. Marking

In these mounting and operating instructions, the safety instructions are specially marked with the following symbols:



Danger

Means danger to life and/or serious property damage in case of non-observance. Never ignore!



Attention

Means that you must pay special attention to the technical relationships.

Unit-specific safety instructions

- ⇒ The fitting is under pressure during operation!
If flange connections, screw plugs or stuffing boxes are unfixed, hot water and steam will escape.
- ⇒ Carry out assembly and maintenance works only if plant is completely pressureless!
- ⇒ The fitting is hot during operation!
Severe burns on hands and arms are possible.
Wait until the unit has cooled before carrying out assembly and maintenance works!
- ⇒ Severe burns and scaldings on the whole body are possible!
- ⇒ Wait until the unit has cooled. In case of opening and disassembling the unit, residual medium can escape. Further evaporation is also possible on pressureless plant.
- ⇒ Sharp-edged interior parts can cause cutting damages on the hands!
Always wear work gloves when exchanging packing, valve seat and valve cone!

Pay attention that the magnetization of the permanent magnets in the unit is not changed! Avoid magnetic fields close to the units!

Exclusion of liability

The IGEMA GmbH Mess- und Regelsysteme does not accept liability when a/m regulations, instructions and warning indications are not observed and adhered to. The operator is responsible for modifications on a unit of IGEMA (if they are not explicitly specified in the mounting and operating instructions).
The magnetic switch may not be opened.
Each warranty claim expires if the test seal is damaged.



2. Important information

2.1 Intended use

Float switch RBJ54/64(63):

The float switch type RBA54/64 can be used as two-point water level controller or limiter according to TRD 401, 402 or 602.

The product according to PED directive 97/23/EEC has the CE-mark no. 0035 of the notified body.

Applied rules as per TRD/AD2000 or ASME Boiler.

| <i>Type</i> | <i>Component mark</i> | <i>EG-component test</i> |
|---------------|-----------------------|--------------------------|
| RBJ 54/64(63) | WRB-04-313 | CE0035-BN0109 |

3. Explanations

3.1 Scope of supply

The unit is delivered as complete unit.

3.2 System description

The float switch (different versions) is used to control or to limit the level of containers and steam generators.

3.3 Function

The unit works according to the physical law of the communicating tubes.

The water level controller or limiter is a float actuated unit where the transmitter magnet connected with the float via the float rod actuates the magnetic switches located inside of the switch housing without direct contact.

4. Technical data

4.1 Versions

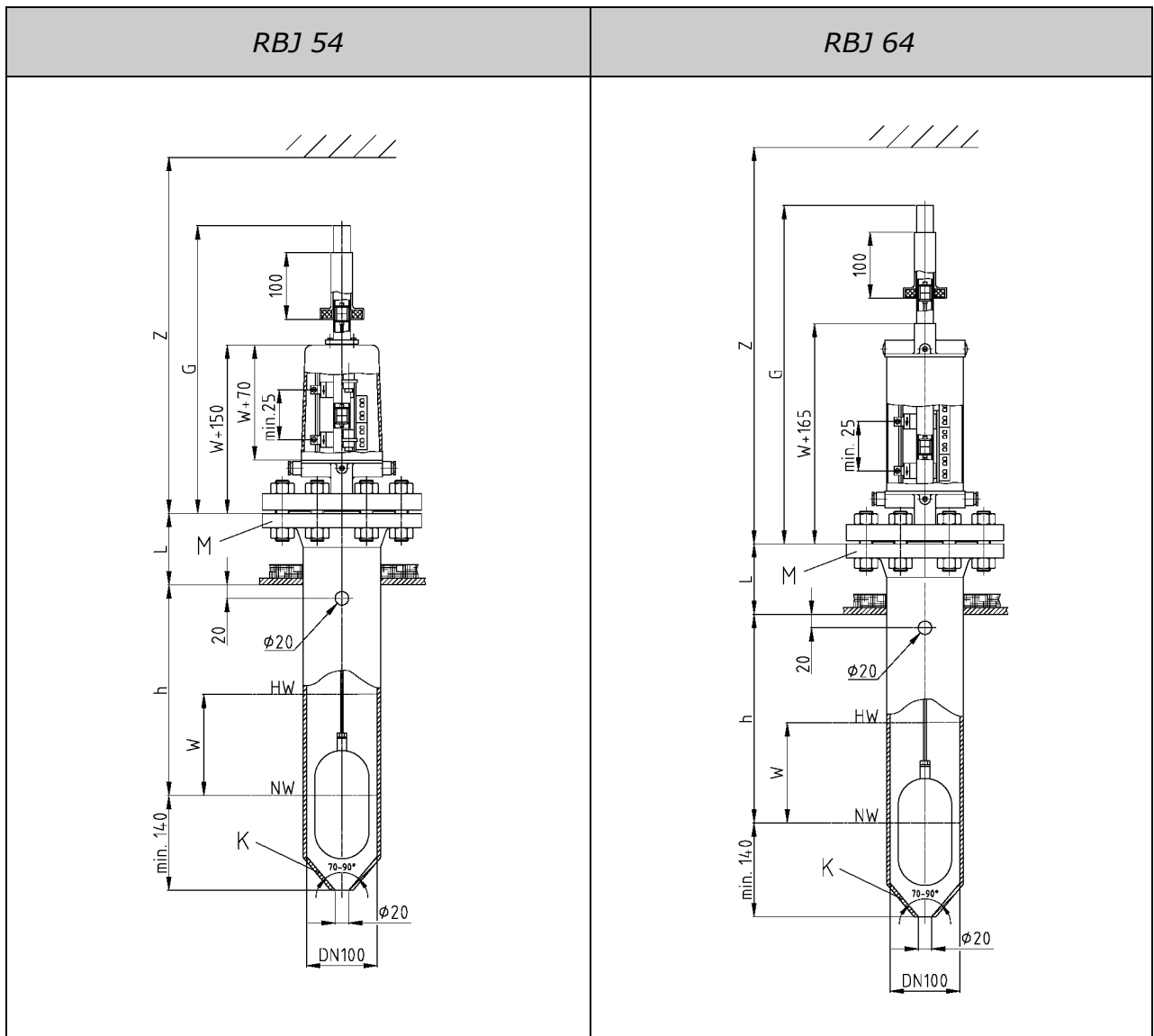

Switch ranges:

| Range of adjustment | W [mm] | | |
|---------------------|--------|-----|-----|
| RBJ 54 | 100 | 150 | |
| RBJ 64 | | | 250 |

Dimensions A, Z:

| Type | Dim. Z [mm] | Dim. G [mm] |
|---------------|-------------|-------------|
| RBJ 54, W=100 | L + H + 410 | 440 |
| RBJ 54, W=150 | L + H + 460 | 550 |
| RBJ 64, W=250 | L + H + 575 | 780 |

(L+H max. 800)

4.2 Type of connection

Flanges DN100 according to DIN

4.3 Materials

Components in contact with the medium and pressure-holding components are made of C steel according to DIN or ASME.

4.4 Application limits

| | | | | | |
|--------------------------------------|-------|-----|-----|-----|-----|
| Nominal pressure | | 16 | 40 | 63 | 100 |
| Max. allowable pressure PS | [bar] | 13 | 32 | 50 | 80 |
| Max. allowable temperature TS | [°C] | 195 | 239 | 265 | 296 |

4.5 Corrosion resistance

The safety of the unit is not influenced by corrosion if it is used as intended.

4.6 Identification plate / Marking

| | | | | |
|---|-----------------|-------------|----------------|--|
|  IGEMA GmbH Mess- und Regelsysteme Zieglerstraße 10-16 Germany - 52078 Aachen CE0035 made by LECOS GmbH a company of the IGEMA group See installation instructions | Built A | | Type B | |
| | PS C bar | | TS D °C | |
| | PN E | DN F | | |
| | | | | |

- a Date of manufacture
- b Type of unit
- c Max. allowable pressure
- d Max. allowable temperature
- e Nominal pressure
- f Nominal diameter

5. Construction

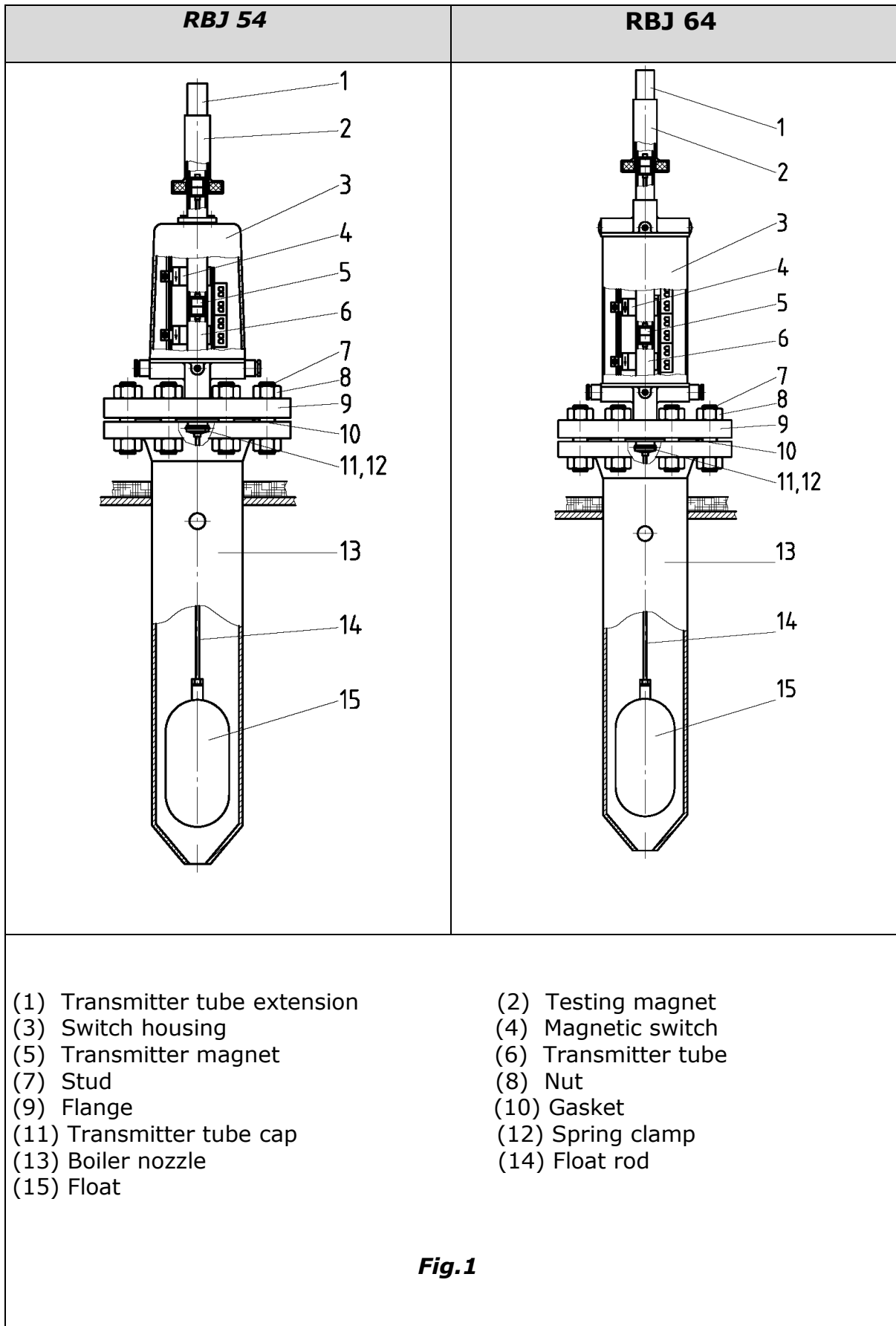

Fig.1

6. Assembly



For assembling, the plant must be pressureless!



Float rod (14) may not be deformed, otherwise danger of malfunction!

- Check correspondence of mating dimensions between flange (9) and vertically welded boiler nozzle (13).
- Ensure that sealing surfaces are clean and undamaged..
- Use sealing material as per EN1514 and screws as per DIN2510 or DIN974 (material 1.7709).
- Carefully remove packing of enclosed float rod (14).
- Insert float rod (14) into transmitter tube (6) and fix by means of transmitter tube cap (11) and spring clamp (12) on transmitter tube.
- Insert device from top into boiler nozzle (13) and screw them together free of tension.
- Tighten up bolts in several Steps using successively opposite diagonal tightening until the tightening torque **MD_{max}** indicated in the table of chapter 7.3 is reached.

7. Electrical connection



Only skilled and qualified personnel may carry out the electrical connection according to the wiring diagram!

Respect the instructions of the VDE (Association for Electrical, Electronic & Information Technologies) and of the local network operators for the installation to be provided by the customer!

Only use cables that are suitable for the operating range!

Observe the switching time of the magnetic switch when designing a safety circuit. Adhere to basic and reliable safety principles as per DIN EN ISO 13849 for electrical components.

7.1 Wiring diagram

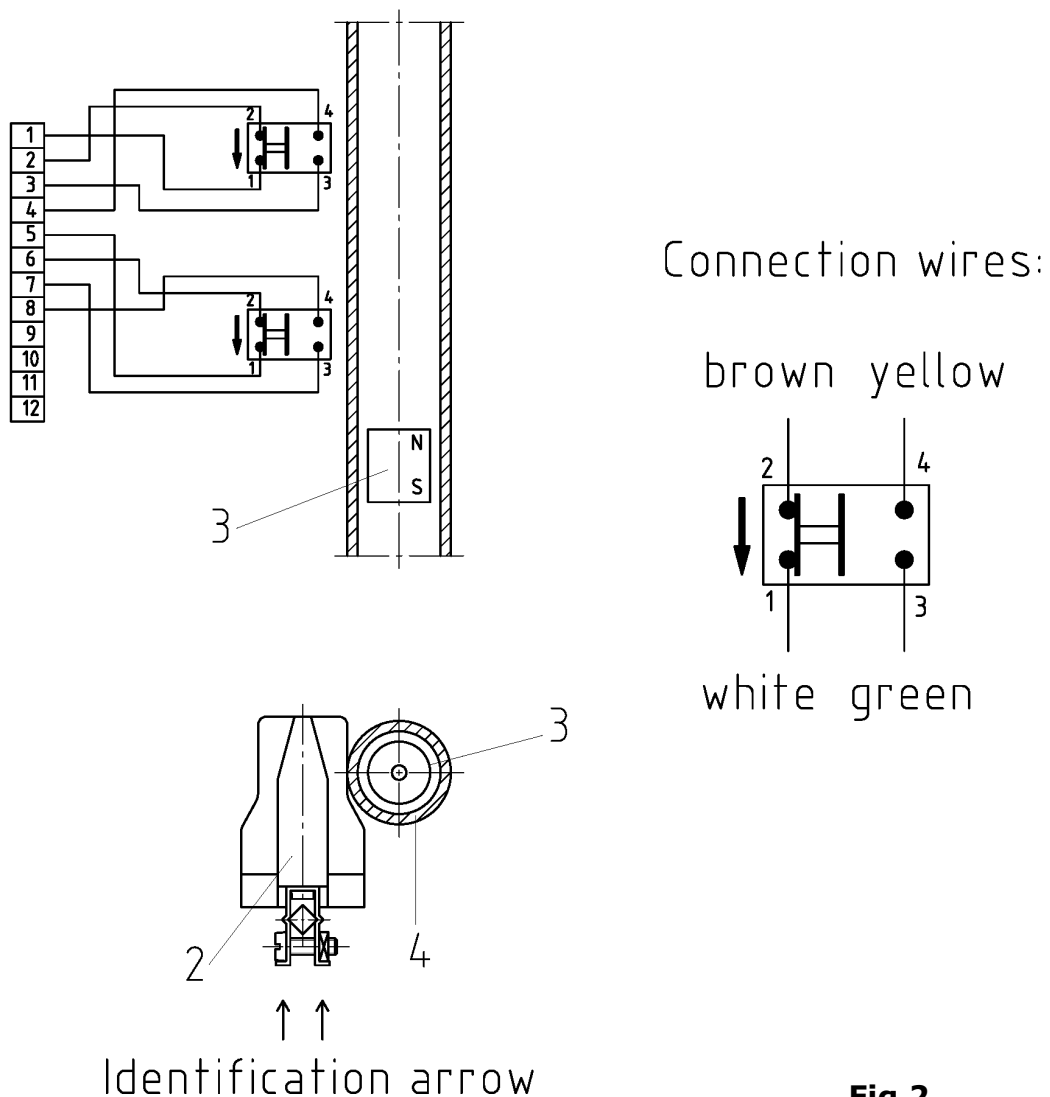

Fig.2

We recommend to use customary RC combinations or a suitable varistor (e.g. 0,1 μ F/100 Ω) as inductive consumer to extend the contact life of the magnetic switch. Resistance value (Ω) and power rating (W) depend on customer indications.

We suggest to use silicon cables free of acetic acid for the further connection cable in the area „connecting housing inside“.

7.2 Connection magnetic switch

- Open switch housing (3) and remove foam cushions between transmitter tube (4) and magnetic switch(es) (2).
- The magnetic switches are already rigidly mounted inside of the switch housing and electrically connected to the terminals (see Fig.2).
- The magnetic switch can be connected optionally as breaker, maker or change-over contact. The switch base is marked with an arrow.
- If the switch is correctly mounted, the arrow should point downwards.
- For technical data of magnetic switch see chapter 7.3.
- Carry out electrical connection.
- Finally ensure that no cable gets in contact with hot elements.

7.3 Technical data magnetic switch

| | |
|--------------------------|---|
| Kind of contact | bistable |
| Contacts | 1 breaker / 1 maker |
| Connection wire | 1 x 0,5 mm ² (16 x \varnothing 0,2) – Cu tinned / PTFE |
| Wire length L | 200 mm |
| All. ambient temperature | -70°C up to +120°C |
| Protection | IP68 |

| Type | Switching voltage U | Switching current I | Max. power UxI |
|---------|---------------------|---------------------|----------------|
| M130-KG | \leq 250 VAC | \leq 1 A | \leq 150 VA |
| | \geq 24 VAC | \geq 0,065 A | \geq 1,5 VA |
| | \leq 24 VDC | \leq 0,008 A | \leq 0,12 VA |

| Type | Article-No. | Contact material |
|---------|-------------|---|
| M130-KG | 15-01122 | Silver-Palladium AgPd 70/30 massiv, hard-gold plated AuCo 4-6 μ m |

8. Commissioning



Unit is hot during commissioning and during operation. Caution!
Danger of burning!

Check specifications of material, pressure and temperature!

- After having reached the operating condition, refill boiler to adjust magnetic switches (4) on corresponding switch height. (see sketch chapter 5)
- The magnetic switch (4) must be correspondingly affixed onto transmitter tube (6).
- Close switch housing (3)

9. Operation monitoring



A function test is prescribed for float switches. Test extend and delays must be specified between operator, boiler manufacturer and local expert (TRD 601, par. 7).

9.1 Function test

The functional test is made by lowering the float device (14,15) below LWL / HWL and by actuating the magnetic switch (4). The prescribed functional test is finished.

- Slowly push down testing magnet (2) over transmitter tube extension (1) protruding of switch housing (3).
- Thus float device (14,15) sinks below LWL / HWL and magnetic switch is actuated (without draining the boiler water). The prescribed functional test is finished.



Remove testing magnet (Fig.1, pos.2) after functional test. Otherwise the instrument continuously announces a water shortage.

10. Maintenance



Check state of the unit during boiler revision, especially float device (Fig.1, pos. 14,15).



Special care must be taken here in order to avoid deforming of the float rod.

10.1 Exchange of float device



For disassembling, the plant must be pressureless!
Wait until the unit has cooled!

- Unfix screw connection (7, 8) (see sketch at chapter 5)
- Lift upper part upwards until float (15) is visible.
- Release transmitter tube cap (11) via spring clamp (12) and remove float device (14) with float (15) out of transmitter tube (6).
- Corroded or deformed parts must be replaced.

10.2 Assembly

- Place transmitter tube cap (11) on transmitter tube (6) and secure with spring clamp (12).
- Check sealing surfaces of flange connection (9) and tighten screw connection (7, 8) by using a new flange gasket (10).
- Tighten up bolts in several steps using successively opposite diagonal tightening until the tightening torque Md_{max} indicated in the table of chapter 10.3 is reached.
- Commissioning see chapter 8

10.3 Tightening torques

| Nominal pressure PN¹⁾ | Allowable pressure PS [bar] | Tightening torques $Md \rightarrow Md_{max}$ [Nm] | | | | | |
|--|--|--|-----|-----|-----|------------|------------|
| | | in steps | | | | | |
| | | 1 | 2 | 3 | 4 | 5 | 6 |
| 40 | 32 | 40 | 65 | 90 | 115 | 145 | - |
| 63 | 50 | 40 | 65 | 90 | 120 | 150 | 185 |
| 100 | 80 | 80 | 110 | 140 | 170 | 195 | 210 |

1) see identification plate

11. Spare parts

Always indicate article no. and serial no. (indicated on the identification plate) in case of spare parts order!

11.1 Float switch

| Pos.-no. | Designation | PN | Article-Nr. | Quantity |
|----------|-----------------|--------|-------------|----------|
| 4 | Magnetic switch | 40-100 | 15-01122 | At order |
| 14 | Float rod | | 15-01128 | 1 |
| 15 | Float | | 40-00918 | 1 |
| 7 | Stud | 16 | 40-00377 | 8 |
| 10 | Gasket | | 40-00192 | 1 |
| 8 | Nut | 40 | 40-00723 | 16 |
| 7 | Stud | | 40-01501 | 8 |
| 10 | Gasket | | 40-00193 | 1 |
| 8 | Nut | 63 | 40-01500 | 16 |
| 7 | Stud | | 40-00409 | 8 |
| 10 | Gasket | | 40-01309 | 1 |
| 8 | Nut | 100 | 40-00734 | 16 |
| 7 | Thread bolt | | 40-00414 | 8 |
| 10 | Sealing ring | | 40-00200 | 1 |
| 8 | Nut | | 40-00737 | 16 |

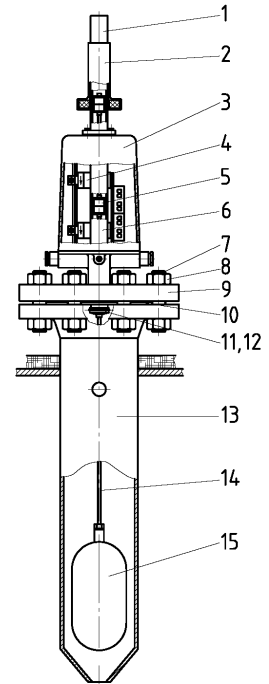

12. Decommissioning



Severe burns and scaldings on the whole body are possible!

Before detaching flange connections, screws of stuffing box etc., all connected lines must be pressureless (0 bar) and cooled off to ambient temperature (20°C)!

12.1 Disposal

Dismount unit and separate waste products.

When disposing the unit, observe legal regulations for waste disposal.

13. Supplement

Warranty

We accord a warranty period of 24 month on our products. A condition for that is the appropriate treatment according to these mounting and operating instructions. The warranty for wear and spare parts is restricted to material defects and construction faults.

The magnetic switches installed in the float switches are wear parts and are **not** included in the warranty.

The sealings/gland packing installed in the valves are **not** included in the warranty.

CE-Declaration of Conformity

Declaration of Conformity in accordance with the PED Directive 97/23/EEC, annex VII,

We, the company:

IGEMA GmbH
LECOS GmbH
J.G. Merckens Mess- und
Regelsysteme GmbH & Co. KG
Zieglerstraße 10-16
52078 Aachen
Deutschland

declare as IGEMA group, that the products „float switches“
with the function LWL limiters / 2-point-controllers
as pressure holding parts

type of product:

RBA 24/25/28/34/35/38
BA 14/18
RBJ 54/58/64/68
BJ 44/48
NA7-45 D

comply with the PED directive 97/23/EEC
and that the following Conformity Assurance System was used

Category IV, module B+D

Applicable standards:
TRD, AD2000, ASME-Boilers

Notified body for the modules:

TÜV Rheinland Industrieservice GmbH
Am Grauen Stein
51105 Köln
Germany

Aachen, 07.11.2006



E.H. Kilchert
(Managing director)



A. Scholl
(QM representative)



P. Barth
(Development)

**IGEMA GmbH
Antwerpener Str. 1
D-48163
Germany**

**Fon.: +49 25 01 9 24 24 0
Fax.: +49 25 01 9 24 24 99**

**info@igema.com
www.igema.com**



This high-quality IGEMA product was designed, manufactured and tested with the application of the QM System guidelines in accordance with DIN EN ISO 9001:2000.

If the device supplied indicates transport damage or gives cause for complaint in spite of our final quality control please contact our SERVICE department on telephone 0241- 5687-0 by return.