



Installation and operating instructions



Remote level gauge

Type FA-G

D-07-B-21107-EN-0.doc

issue date 07/2017

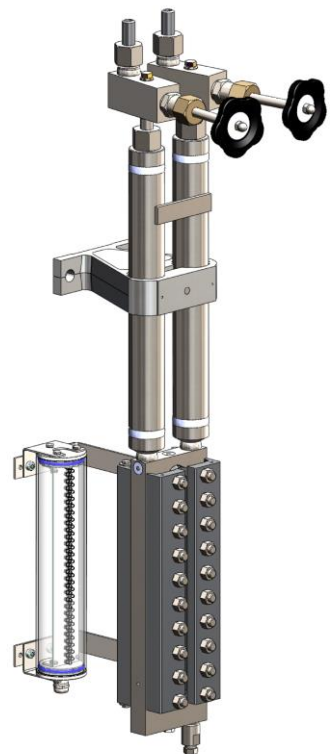

- ⓘ Table of contents-

1.	Health and safety instructions	4-5
1.1	General health and safety instructions	4
1.2	Unit-specific safety instructions	5
1.3	Exclusion of liability	5
2.	Important information	6
2.1	Intended use	6
3.	Explanations	6
3.1	Scope of supply	6
3.2	System description	6
3.3	Function	6
4.	Technical data	7-8
4.1	Versions	7
4.2	Type of connection	8
4.3	Materials	8
4.4	Application limits	8
4.5	Corrosion resistance	8
4.6	Identification plate / Marking	8
5.	Construction	9
6.	Assembly	10
6.1	Version with flange	10
6.2	Version with butt welding end	10
6.3	Remote level gauge	10
7.	Commissioning	10-11
7.1	Cleaning of connection lines (f)	10-11
7.2	Commissioning of remote level gauge	11
7.3	Adjustment of separating liquid	11

8.	Operation	12
8.1	Operation monitoring Betriebsüberwachung	12
8.2	Decommissioning of boiler	12
9.	Maintenance	12-13
9.1	Cleaning of connection lines (f)	12
9.2	Cleaning of remote level gauge	13
9.3	Replacement of glasses	13
9.4	Tightening torques.....	13
10.	Shutoff valves	14-16
10.1	General information and operating instructions	14
10.2	Construction	14-15
10.3	Indicator valve (h,j).....	15-16
10.4	Main shutoff valve (c,g).....	16
11.	Spare parts	17-18
11.1	Remote level gauge	17
11.2	Main shutoff valve	17
11.3	Indicator valve	18
12.	Decommissioning	18
12.1	Disposal	18
13.	Supplement	18
13.1	Warranty	18



Safety instructions



General health and safety instructions

1. Avoidance of danger for persons and property

- Only use unit for intended purpose.
- No additional mountings and modifications on the unit without our approval.
- Adhere to the standards for prevention of accidents and to the plant specific safety regulations.
- Read and observe installation and operating instructions.

2. Application limits

Only use this unit according to these operating instructions and to the parameters agreed upon in the delivery contract (see identification plate) including the agreed operating conditions.

3. Avoidance of danger and damages

- Distribute these mounting and operating instructions to appropriate department "arrival of goods, works transport, mounting, commissioning and maintenance".
- When passing the unit to a third party, these mounting and operating instructions must be enclosed in the national language of this third party.
- Only skilled and qualified personnel with special work order may work on the unit, which must be free of pipeline stress!
- Carefully read, observe and preserve these mounting and operating instructions.
- **Observe and adhere to the precautions marked in bold characters in the sections of these mounting and operating instructions!**
- Avoid shocks and impacts during transport, which could damage the unit.
- In case of intermediate storage take care for a dry and appropriate place where the unit cannot be damaged.

4. Marking

In these mounting and operating instructions, the safety instructions are specially marked with the following symbols:



Danger

means danger to life and/ or serious property damage in case of non-observance. Never ignore!



Attention

means that you must pay special attention to the technical relationships.

Unit-specific safety instructions

- ⇒ The fitting is under pressure during operation!
If flange connections, screw plugs or stuffing boxes are unfixed, hot water and steam will escape.
- ⇒ Carry out assembly and maintenance works only if plant is completely pressureless!
- ⇒ The fitting is hot during operation!
Severe burns on hands and arms are possible.
Wait until the unit has cooled before carrying out assembly and maintenance works!
- ⇒ Severe burns and scaldings on the whole body are possible!
- ⇒ Wait until the unit has cooled. In case of opening and disassembling the unit, residual medium can escape. Further evaporation is also possible on pressureless plant.
- ⇒ Sharp-edged interior parts can cause cutting damages on the hands!
Always wear work gloves when exchanging packing, valve seat and valve cone!

Exclusion of liability

The IGEMA GmbH Mess- und Regelsysteme does not accept liability when a/m regulations, instructions and warning indications are not observed and adhered to. The operator is responsible for modifications on a unit of IGEMA (if they are not explicitly specified in the mounting and operating instructions).

2. Important information

2.1 Intended use

Remote level gauge:

The remote level gauge type GS can be used for every steam generator according to TRD 401 except continuous steam generators. In the sight opening, a float indicates the water level in the passage between water and steam.

Applied rules as per TRD/Ad2000 or ASME-Boilers.

3. Explanations

3.1 Scope of supply

Remote level gauge:

The level gauge is delivered as unit A, B and C.

Unit A consists of:

- Level gauge (k)
- Indicator valves (h, j)

Unit B consists of:

- Upper main shutoff valve (c) with condenser (b)
- Lower main shutoff valve (g)

Unit C consists of:

- Illumination device (p)

3.2 System description

The type FA GS is used to indicate the water level of steam generators.

3.3 Function

The level gauge works according to the physical law of the communicating tubes.

The geodetic pressure difference of two water columns is transferred to a transparent separating liquid in the remote level gauge. This liquid is not soluble in water and non-toxic.

A signal float swimming on separating liquid reports water level in steam drum on a scale of 1:1 or on a reduced scale.

4. Technical Data

4.1 Versions

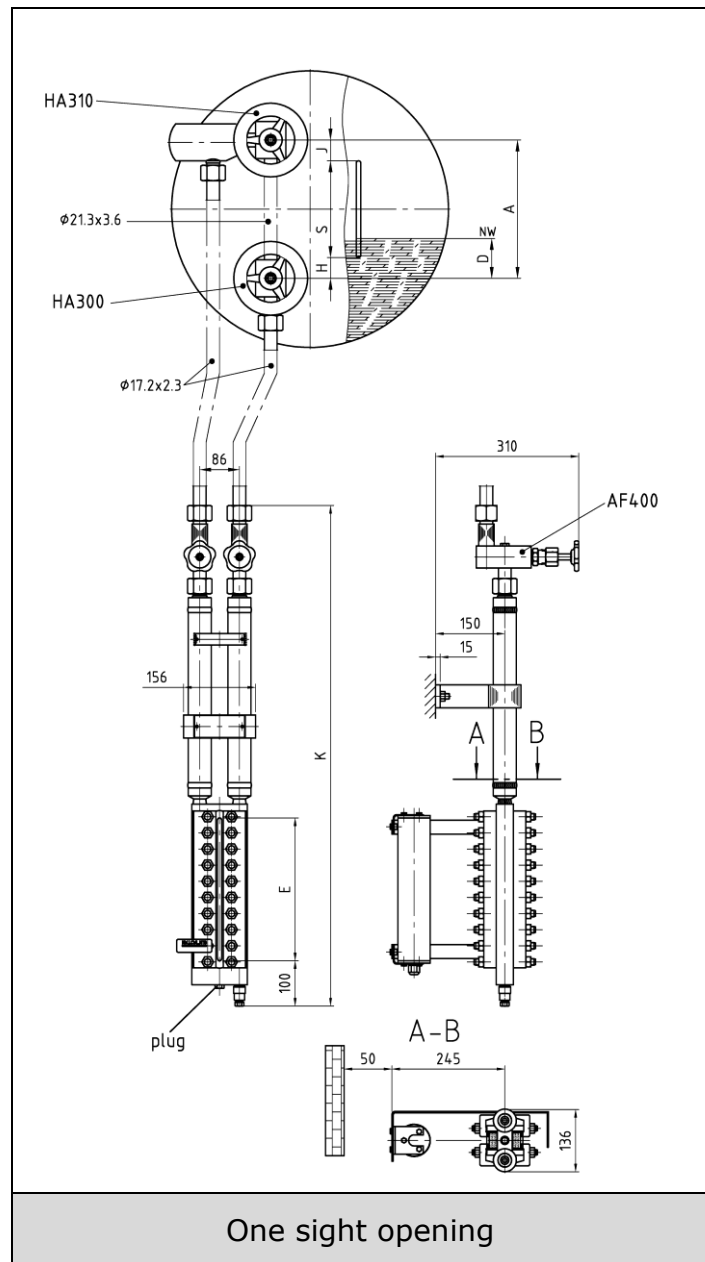

Sight openings:

All. pressure	PS [bar]	10-50	80-200
Sight opening	S [mm]	470 (on request)	---
		310 oder 390	
All. temperature of remote level gauge and indicator valve	TS [°C]	2 bis 40	

4.2 Type of connection

Standard : flanges according to DIN

On request : flanges according to ASME
Buttwelding end according to DIN or ASME

4.3 Materials

Parts in contact with the medium: C steel or stainless steel according to DIN or ASME.

Pressure holding components: C steel or stainless steel according to DIN or ASME.

4.4 Application limits

Max. all. pressure PS	[bar]	10-200
Max. all. temperature TS	[°C]	40

4.5 Corrosion resistance

The safety of the unit is not influenced by corrosion if it is used as intended.

4.6 Identification plate / Marking

 IGEMA GmbH Mess- und Regelsysteme Zieglerstraße 10-16 Germany - 52078 Aachen made by LECOS GmbH a company of the IGEMA group See installation instructions	Built A		Type B		
	PS C		bar	TS D	°C
	PN E	DN F			

- a Date of manufacture
- b Type of unit
- c Max. all. pressure
- d Max. all. temperature
- e Nominal pressure
- f Nominal diameter

5. Construction

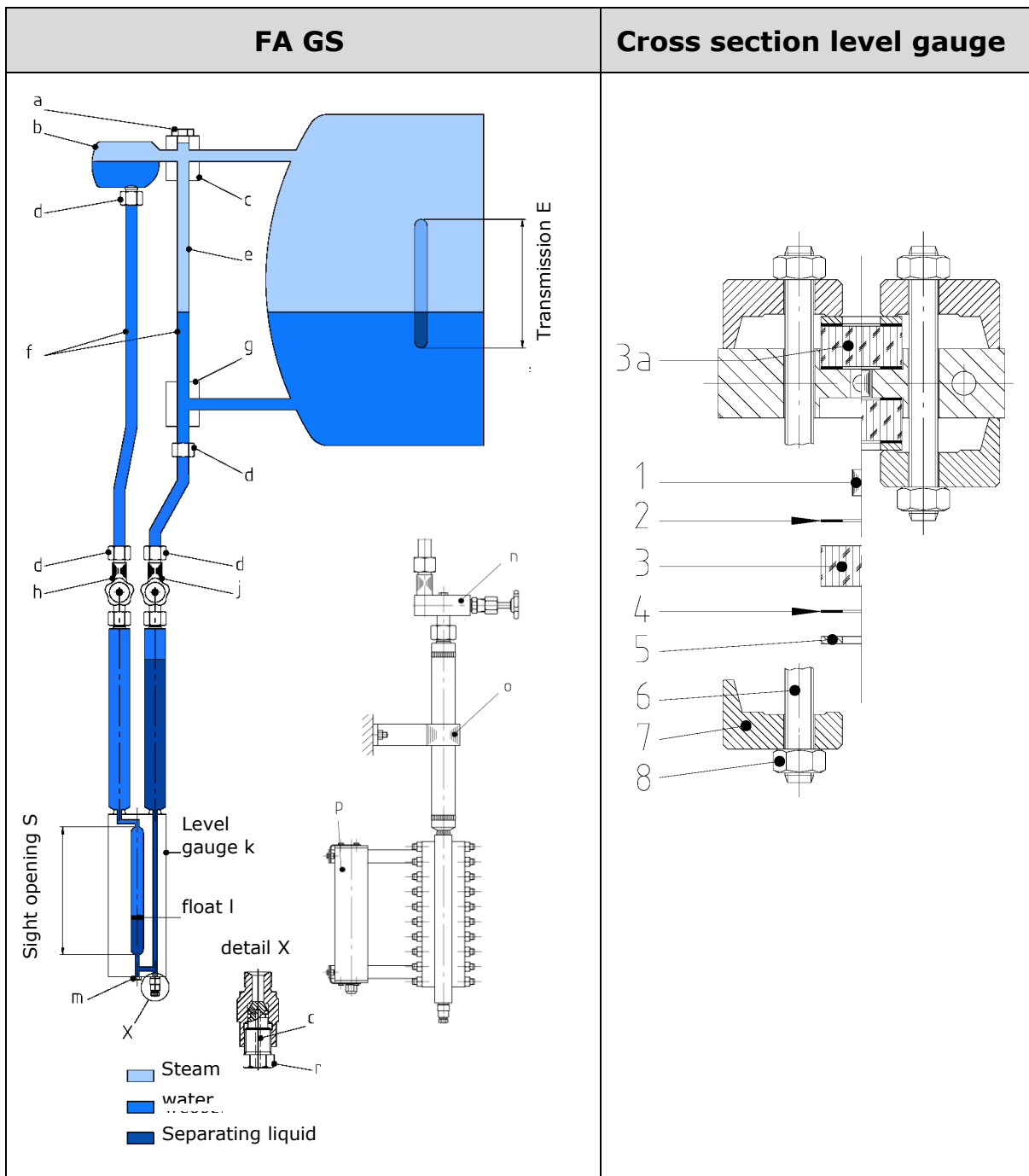

- (a) Vent plug
- (b) Condensor
- (c) Upper main shutoff valve
- (d) Bolting
- (e) Balance pipe
- (f) Connection line
- (g) Lower main shutoff valve
- (h) Indicator valve
- (j) Indicator valve
- (k) Level gauge
- (l) Float (1)

- (m) Plug
- (n) Plug
- (o) Supporting clamp
- (p) Illumination device
- (q) Drain opening
- (r) Adjusting screw

- (1) Float
- (2) Sealing
- (3) Glass
- (3a) Glass, matted
- (4) Cushion
- (5) Pressure plate
- (6) Cover screw
- (7) Cover rail
- (8) Hexagon nut

6. Assembly

6.1 Version with flange

- Respect installation position!
- Remove protection caps from connection flanges. Caps *only* serve as transport protection.
- Ensure that sealing surfaces are clean and undamaged.
- Use sealing material as per EN1514 and screws as per DIN2510 or DIN974 (material 1.7709).
- Mount main shutoff valves.

6.2 Version with butt welding end

- Respect installation position!
- Remove protection caps from connection flanges. Caps *only* serve as transport protection.
- Assembly only by using welding process 111 (manual arc welding) and 141 (tungsten inert gas welding).

6.3 Remote level gauge

- Fix level gauge (k) via supporting clamp (o).
- Connect main shutoff valves (c) and (g) on boiler studs.
- Weld on balance pipe (e) and lay connection lines (f) with constant slope to avoid air locks during operation.
- Weld on connection bolting (d) on the ends of connection lines (f). Check sealing and sealing surface of the bolting (d).
- Tighten firmly bolting (d) on condenser (b) and shutoff valve (g).
- Mount illumination device (p) and carry out electrical connection observing the VDE 0100 and the current regulations.
- Boiler manufacturer or operator have to ensure that filling (separating liquid and water) in level gauge (k), connection lines (f) and condenser (b) can neither freeze nor vaporise.

7. Commissioning

7.1 Cleaning of connection lines (f)

- Close main shutoff valves (c) and (g). Detach connection lines (f) on indicator valves (h) and (j) and on bolting (d) and bend a little to the side.

Cleaning of connection lines can be made in two ways:



Ensure that nobody stays next to detached bolting of indicator valves (h) and (j)!

- a. Remove vent plug (a) and purge connection lines (f) with water through this opening.

- b. Bring boiler to operating condition with firmly tightened vent plug (a) and purge connection lines (f) by opening and closing several times main shutoff valves (c) and (g).
- Tighten firmly detached connection lines on indicator valves (h) and (j).

7.2 Commissioning of remote level gauge

Fill level gauge and connection lines with water and separating liquid in the following order to avoid air locks.

- Close tightly main shutoff valves (c, g) and indicator valves (h, j).
Check bolts of adjusting screw (r) and plug (m).
Unscrew plugs (a, m and n).
- Fill in water at plug (n) on indicator valve (j) until water level attunes in highest sight opening.
Then fill in separating liquid until level of separating liquid attunes in highest sight opening.
Additionally fill in a quantity of about 10 cm³ of separating liquid.
(Marking "seperating liquid" is written on the bottle.)



Respect safety regulations on bottle of separating liquid.
These safety regulations are also specified on a safety data sheet.
Use separating liquid within a year.

- Fill in clean water up to overflowing at plug (n) on indicator valve (h). Firmly tighten plug (n) with sealing.
- Fill in clean water up to overflowing at plug (n) on indicator valve (j). Firmly tighten plug (n) with sealing.
- Slowly fill in clean water up to overflowing at vent plug (a) of main shutoff valve (c).
Both shutoff valves (c, g) must be closed. Tighten vent plug (a) with sealing.
- After having reached a minimum operating pressure of 2 bar, open valves in the following order: c, g, h and j.
- Check all bolts and tighten if necessary during start up of the boiler. Recheck all bolts and tighten after several operating hours.

7.3 Adjustment of separating liquid

Adjustment of separating liquid level is made during boiler operation with average water level.

Temporary open adjusting screw (r) several times to drain as much separating liquid through the drain opening (q) until indication coincides with water level of direct water level gauge.

In case of larger deviation, adjustment must be accomplished gradually with short breaks.

The separating liquid to be drained must be collected in a container. Respecting safety regulations for separating liquid.

(Marking "seperating liquid" is written on the bottle.)



If too much separating liquid has been filled in or if too little has been drained, see point 7.2 for further proceeding.

8. Operation

8.1 Operation monitoring

Regularly compare level of separating liquid with water level of direct water level gauge. Non-conformance may have the following reasons:

- Indicator valves (h, j) are not opened.
Open first indicator valve (h) and then valve (j).
- Main shutoff valves (c, g) are not opened.
Close opened indicator valves (h, j). Opening valves in the following order: c, g, h and j.
- Condenser (b) is not hot enough; no condensation.
Carefully turn vent plug (a) once and vent condenser (b). Firmly close vent plug again.
- Handling error during opening of valves.
Draining of separating liquid as per 7.2.
Following measures as per 7.2/7.3.
- Liquid level comparatively too high.
Adjustment following 7.3.

Regularly check tightness of valves (c, g, h and j) and retighten gland packing if necessary.



Fully open valve spindles to release gland packing of indicator (h, j) and main shutoff valves (c, g) in operating condition.

8.2 Decommissioning of boiler

- Close indicator valves (h, j) in any case of decommissioning.
In case of longer boiler stagnation, also close shutoff valves (c, g).
- Open valves for re-commissioning in following order: c, g, h and j.
- If boiler is in operating condition, pay attention that operating temperature on condenser (b) is sufficient. Vent condenser (b) as per 8.1 if necessary.

9. Maintenance



Carry out maintenance works only if connection lines (f) are empty and pressureless!
Beware of escaping steam!

9.1 Cleaning of connection lines (f)

- Close valves (h, j, c, g).
- Use vent plug (a) to make level gauge and connection lines (f) pressureless.
Turn vent plug (a) once.
- Further measures as per point 7.1.
Commissioning of level gauge as per 7.2./ 7.3.

9.2 Cleaning of level gauge

Close indicator valves (h, j). Carefully unfasten plug (n) on main shutoff valves (c, g) to relieve high pressure of level gauge (k). Remove plug (n).

- Drain separating liquid through drain opening (q) by unfastening adjusting screw (r) and collect liquid in a container. Respect safety regulations of "seperating liquid".
(Marking "seperating liquid" is written on the bottle.)
Observe enclosed saftey data sheet!
- Remove plug (m). Purging of level gauge with water through plug (n). Insert circular brush in opening at plug (m) during purging and clean glasses through opening at plug (n) on indicator valve (h). Firmly tighten adjusting screw (r) and plug (m).
- For filling and adjusting level gauge with connection lines see points 7.2 and 7.3.

9.3 Replacement of glasses

- Loosen screws (6, 8) and remove cover rail (7), pressure plate (5), glasses (3, 3a) and float (1). Carefully remove cushion (4) and sealing (2) without damaging supporting and sealing surfaces.
- Clean supporting and sealing surfaces and assemble with new sealings (2), glasses (3, 3a), float (1) and cushions (4) in the illustrated order.

Mount glass (3a) with matted side backwards to illumination device!

Tighten screws (6, 8) from top to bottom starting in the middle of sight opening
Using successively opposite diagonal tightening

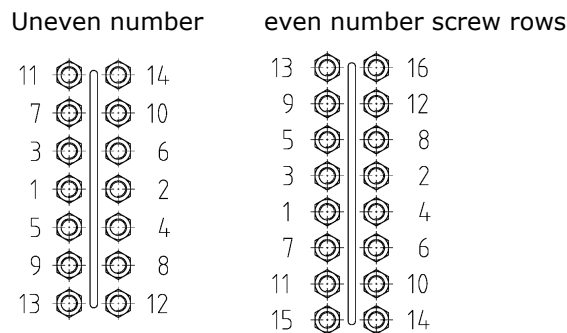

9.4 Tightening torques

All. pressure PS	Tightening torque Md → Md_{max} [Nm]				
	In steps				
	1	2	3		
≤100	35	50	65	-	-
>100	45	60	75	90	105

10. Shutoff valves

10.1 General information and operating instructions

IGEMA valves are mostly maintenance-free and easy to handle. All IGEMA valves are equipped with metal gaskets and hand operation. Sealing of valve spindle is made with a gland packing.

Turn handwheel clockwise to close the valve.

Turn handwheel counterclockwise to open valve.

Tools to increase hand torque are not permitted.

10.2 Construction

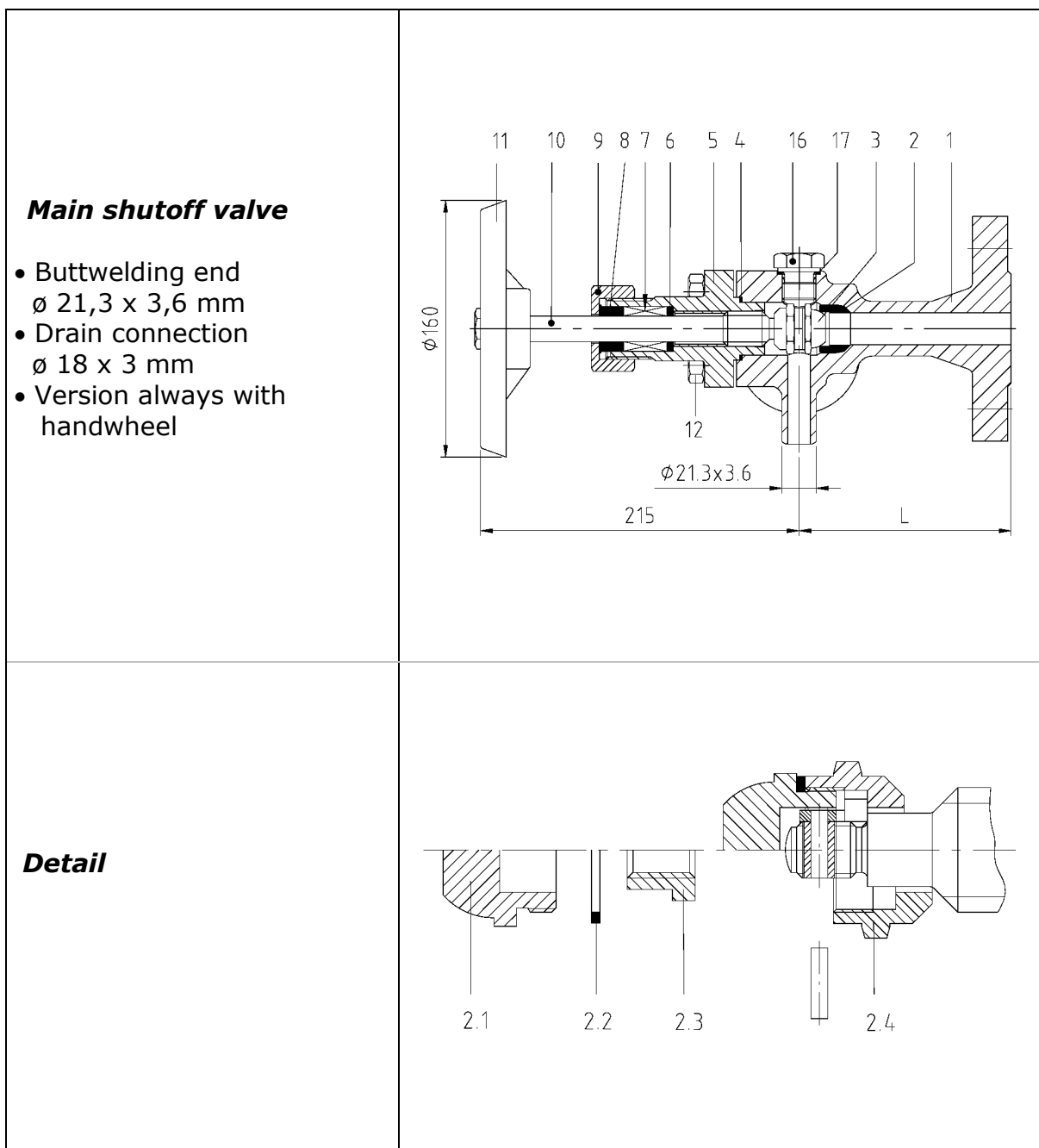

Indicator valve

- process connection
ø 17,2 x 2,3 mm
- Version always with
handwheel

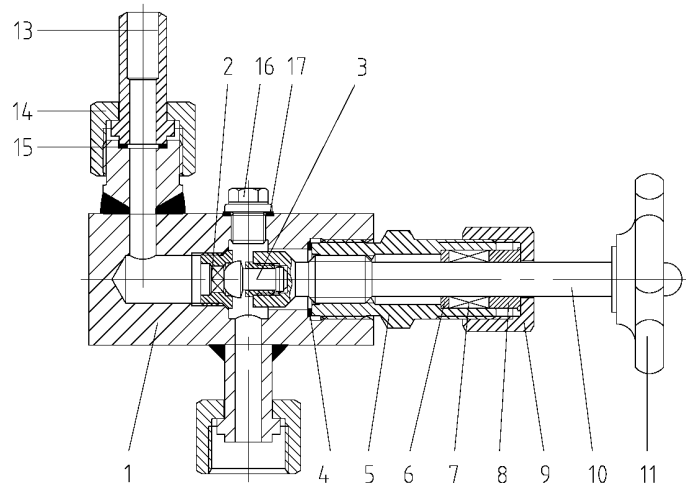

- | | | |
|-------------------------|-------------------|---------------------|
| (1) Valve housing | (11) Handwheel | (2.1) Cone half |
| (2) Seat | (12) Nut | (2.2) Sealing ring |
| (3) Cone set | (13) weld ferrule | (2.3) Clamping ring |
| (4) Sealing ring | (14) Screw cap | (2.4) Cone half |
| (5) Upper part of valve | (15) Sealing ring | |
| (6) Base ring | (16) Screw plug | |
| (7) Gland packing | (17) Sealing | |
| (8) Gland | | |
| (9) Screw cap | | |
| (10) Valve spindle | | |

10.3 Indicator valve (h, j)



Carry out maintenance works only if connection line (f) is empty and pressureless!
Beware of escaping steam!

- Close valves (h, j, c and g) and carefully turn vent plug (a) once.
- Remove vent plug (a) and plug (n) of indicator valve which should be maintained (h or j). Unscrew upper part of valve (5) with valve spindle (10).

Replacement of seat (9) and cone set (3):

Replace cone set (3).

Unscrew seat with hexagon socket wrench SW 10 and replace.

Tightening torque **Md = 70 Nm**.

Replacement of gland packing (7):

Loosen screw cap (9) and unscrew valve spindle (10) clockwise from thread of upper part of valve (5).

Loosen handwheel (11) and push valve spindle (10) out of gland packing (7).

Carefully remove deposits on valve spindle.

Take off screw cap (9) and gland (8) and push out gland packing to be replaced over base ring (6).

Assembly in following order:

Screw in valve spindle (10), insert base ring (6) - gland packing (7) - and gland (8), place and tighten screw cap (9).

Fix handwheel (11). Tighten valve spindle (10) counterclockwise in upper part of valve (5) as far as it will go.

Insert upper part of valve (5) with valve spindle (10) and new sealing ring (4) in valve housing (1) and tighten.

10.4 Main shutoff off valve (c, g)



Carry out maintenance works only if boiler is pressureless and empty below valve stud.

- Loosen nut (12) and remove upper part of valve (5) with valve spindle (10).

Replacement of seat (20) and cone (21):

Cone parts (2.1, 2.2, 2.4) loosen cone halves (2.1, 2.4) which are screwed together.

Unfasten pinned clamping nut (2.3) and remove cone half.

Assembly with parts to be replaced in reverse order:

See detail for assembly of cone halves (2.1, 2.4) and sealing ring (2.2).

Screw cone halves (2.1, 2.4) together.

Remove seat with special wrench and replace.

Tightening torque **Md = 100 Nm**.

Replacement of gland packing (7) as described under 9.3.

Insert upper part of valve (5) with new sealing (4) and tighten nuts (12) using successively opposite diagonal tightening. Tightening torque **Md = 60 Nm**.

11. Spare parts

Always indicate article no. and serial no. (indicated on the identification plate) in case of spare parts order!

11.1 Remote level gauge

für S=310

Pos. no.	Article-no.		Quantity	Designation	Material
	≤100	>100			
1	40-01996		1	float, red	PVC- rigid
2	40-00247		2	Sealing	Graphite-steel
3	40-00007	40-00026	1	Glass	Borosilicate
3a	40-00014	40-00031	1	Glass, matted	Borosilicate
4	40-00090		2	Cushion	Aramid fiber
5	40-00429		2	Pressure plate	RSt 37.2
6	40-00355	40-00368	20	Threaded bolt	1.7709
7	25-01085	25-01290	4	Cover rail	1.0425
8	40-00583	40-00716	40	Hexagon nut	1.7258
D	40-01365		2	Sealing ring	1.4541
m	40-00327		1	Screw plug	1.4300
	40-01242		1	Sealing ring	1.4541
x	40-00123		1	Sealing ring	1.4541
	15-04135		1	Drain screw	1.4021

für S=390

Pos. no.	Article-no.		Quantity	Designation	Material
	≤100	>100			
1	40-01996		1	float, red	PVC- rigid
2	40-00248		2	Sealing	Graphite-steel
3	40-00010	40-00028	1	Glass	Borosilicate
3a	40-00015	40-00032	1	Glass, matted	Borosilicate
4	40-00093		2	Cushion	Aramid fiber
5	40-00420		2	Pressure plate	RSt 37.2
6	40-00355	40-00368	24	Threaded bolt	1.7709
7	25-01277	25-01296	4	Cover rail	1.0425
8	40-00583	40-00716	48	Hexagon nut	1.7258
d	40-01365		2	Sealing ring	1.4541
m	40-00327		1	Screw plug	1.4300
	40-01242		1	Sealing ring	1.4541
x	40-00123		1	Sealing ring	1.4541
	15-04135		1	Drain screw	1.4021

11.2 Main shutoff valve

Pos. no.	Article- no.	Qty.	Designation	Material
2,3	15-00297	1	Cone set with seat	1.4034 / 1.4104
17	40-00099	1	Sealing ring	1.0338.03
18	40-00331	1	Screw plug	1.0711
4	40-00120	1	Sealing ring	1.0338.03
6,7,8	15-00112	1	Gland packing	Graphit
9	25-00662	1	Screw cap	1.0711
10	15-02690	1	Spindle	1.4104
11	15-00419	1	Handwheel assembly	Aluminium / Stahl
15	40-00113	2	Sealing ring	1.0338.03
14	25-01143	2	Screw cap	1.0711
13	25-00744	2	Weld ferrule	1.0460

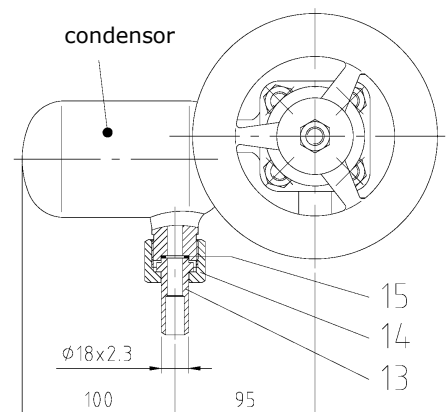

11.3 Indicator valve

Pos. no.	Article-no.	Quantity	Designation	Material
13	25-00744	1	Weld ferrule	1.0305
14	25-01144	1	Screw cap	Stainless steel
15	40-01365	1	Sealing ring	
2,3	15-00114	1	Cone set with seat	
16	40-00327	1	Plug	
17	40-01242	1	Sealing ring	
4	40-00129	1	Sealing ring	
6,7,8	15-00295	1	Gland packing	Graphite
9	25-00657	1	Screw plug	Stainless steel
10	25-00557	1	Valve	
11	15-00669	1	Handwheel assembly	plastic

12. Decommissioning



Severe burns and scaldings on the whole body are possible!

Before detaching flange connections, screws of stuffing box cover screws or screw plugs, all connected lines must be pressureless (0 bar) and cooled off to ambient temperature (20°C)!

12.1 Disposal

Dismount unit and separate waste products.

When disposing the unit, observe legal regulations for waste disposal.

13. Supplement

13.1 Warranty

We accord a warranty period of 24 month on our products. A condition for that is the appropriate treatment according to the operating instructions. The warranty for wear and spare parts is restricted to material defects and construction faults.

The glasses, separating liquid and sealing rings in the level gauge are wear parts and are **not** included in our warranty.

The sealings/gland packing installed in the valves are **not** included in the warranty.

**IGEMA GmbH
Antwerpener Str. 1
D-48163
Germany**

**Tel.: +49 25 01 9 24 24 0
Fax.: +49 25 01 9 24 24 99**

**info@igema.com
www.igema.com**



This high quality IGEMA product has been developed, manufactured and inspected in accordance with a quality management system according to DIN EN ISO 9001:2000.

If on receipt of this unit you notice damage in transit or another cause for complaint despite our final quality inspection, please contact immediately our customer service, phone no. +49 (0) 241-56 87-0.